

**power**technique

**PT505**

Voltage (V): **400/230**

Frequency (Hz): **50**

**STATIONARY OPENSET  
AUTOMATIC WITHOUT ATS**

## Technical Information

PRP Power (Kva)	<b>462</b>
Standby Power	<b>506</b>
PRP Power (Kw)	<b>369.6</b>
Standby Power (Kw)	<b>404.8</b>
Model	<b>STATIONARY OPENSET</b>

Weight and Dimensions (mm)	
Length (L)	<b>3810</b>
Width (W)	<b>1200</b>
Height (H)	<b>2365</b>
Weight (kg)	<b>4475</b>
Fuel tank capacity (l)	<b>943</b>

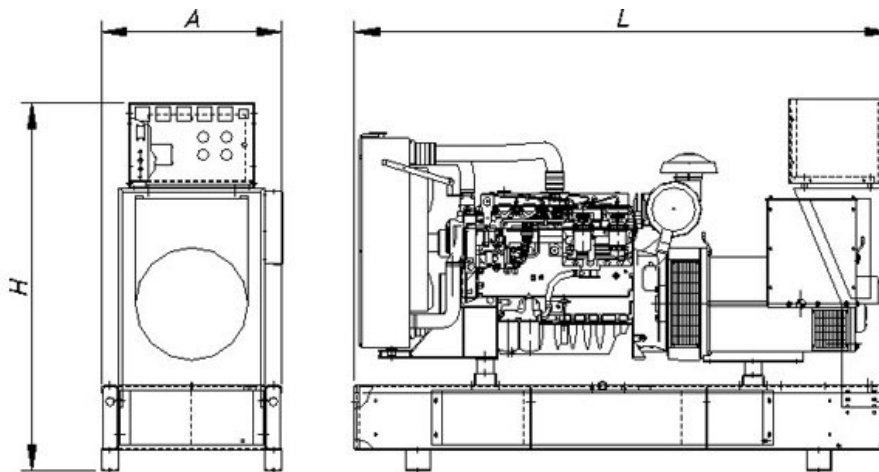

## Consumption

	PRP Power		Standby Power	
	L/h	Range (hours)	L/h	Range (hours)
25%	25	37.7	26.6	35.5
50%	44.7	21.1	48.4	19.5
75%	65.3	14.4	71.2	13.2
100%	88	10.7	97.3	9.7

## Engine

Brand	VOLVO
Model	TAD 1640 GE
Electronic management	✓
No. of Cylinders	6
Engine Capacity	16120
Bore (mm)	144
Stroke (mm)	165
Compression ratio	17.5:1
Water cooled	✓
Speed (r.p.m.)	1500
Preheating system	✓
Fuel tank capacity (l)	943

### Cooling System

Flow of air from fan (m3/min)	475
-------------------------------	-----

### Lubrication System

Oil sump capacity (l)	48
Maximum oil consumption (%fuel consumption)	0.1

### Air Intake System

Aspirated air flow (m3/min)	36.2
-----------------------------	------

### Electrical System

Batteries	12V 140 Ah
-----------	------------

### Exhaust System

Input diameter (")	6
Output diameter (")	7.6
Exhaust diameter (mm)	300
Exhaust length (mm)	1,945
T <sup>a</sup> gas emission (°C)	456
Gas flow	85.4

## Alternator

Model	HCI 5_4 C1
Electronic Regulation	✓
AVR	SX440
Power (Kva)	520

## Electric Panel

### Measuring Instruments

Voltmeter	1
Battery current gauge	✓

### Control Instruments

Control card	DEEP SEA
Auto start-up. Mains failure	✓
Manual start-up	✓
Remote start-up	✓

### Alarms

Start-up failure	✓
Battery charge failure	✓
Low oil pressure	✓
High engine water temperature	✓
Low fuel level	✓
Low radiator water level	✓
Emergency stop	✓
Overspeed	✓

<b>Standby Gensets</b>	
3-phase tracking card	✓
Battery charger maintainer	✓
Voltmeter. Switch: PHASE-MAINS-GENSET	✓
Auto/manual function	✓
LED indicators MAINS/GENSET switch	✓
Remote control software	✓
RS 485 communication port	✓
<b>Protection Devices</b>	
Emergency stop button	✓

**Head office address:**

Unit 4, Concorde Close, Sopwith Park,  
 Segensworth North, Fareham, Hampshire, PO15 5RT. UK  
 Tel: +44 (0)1489 560700 Fax: +44 (0)1489 560742  
[sales@powertecnicue.com](mailto:sales@powertecnicue.com) [www.powertecnicue.com](http://www.powertecnicue.com)

Power Tecnicue Ltd reserves the right to modify any characteristic without prior notice. Photos or drawings are based on standard product, being possible to add optional elements