

powertechnique

PT505

Voltage (V): **400/230**

Frequency (Hz): **50**

STATIONARY OPENSET

AUTOMATIC WITH ATS

Technical Information

PRP Power (Kva)	462
Standby Power	506
PRP Power (Kw)	369.6
Standby Power (Kw)	404.8
Model	STATIONARY WOPENSET

Weight and Dimensions (mm)	
Length (L)	3810
Width (W)	1200
Height (H)	2365
Weight (kg)	4475
Fuel tank capacity (l)	943

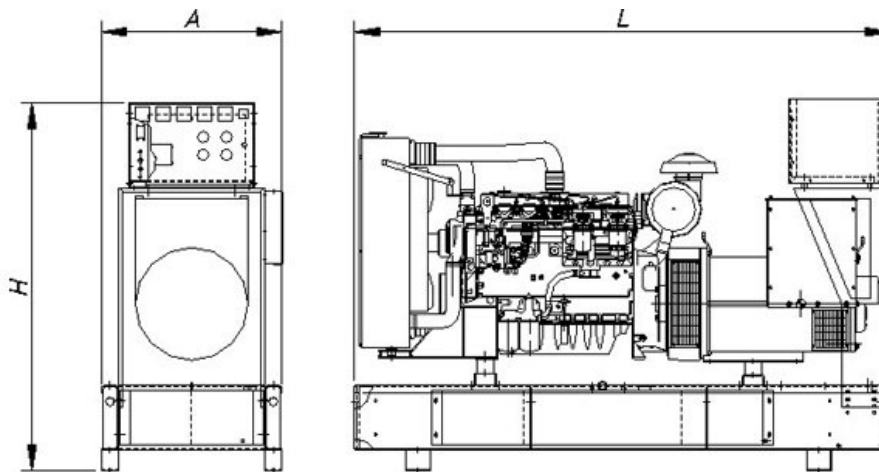

Consumption

	PRP Power		Standby Power	
	L/h	Range (hours)	L/h	Range (hours)
25%	25	37.7	26.6	35.5
50%	44.7	21.1	48.4	19.5
75%	65.3	14.4	71.2	13.2
100%	88	10.7	97.3	9.7

Engine

Brand	VOLVO
Model	TAD 1640 GE
Electronic management	✓
No. of Cylinders	6
Engine Capacity	16120
Bore (mm)	144
Stroke (mm)	165
Compression ratio	17.5:1
Water cooled	✓
Speed (r.p.m.)	1500
Preheating system	✓
Fuel tank capacity (l)	943

Cooling System

Flow of air from fan (m3/min)	475
-------------------------------	-----

Lubrication System

Oil sump capacity (l)	48
Maximum oil consumption (%fuel consumption)	0.1

Air Intake System

Aspirated air flow (m3/min)	36.2
-----------------------------	------

Electrical System

Batteries	12V 140 Ah
-----------	------------

Exhaust System

Input diameter (")	6
Output diameter (")	7.6
Exhaust diameter (mm)	300
Exhaust length (mm)	1945
T ^a gas emission (°C)	456
Gas flow	85.4

Alternator

Model	HCI 5_4 C1
Electronic Regulation	✓
AVR	SX440
Power (Kva)	520

Electric Panel

Measuring Instruments

Voltmeter	1
Battery current gauge	✓

Control Instruments

Control card	DEEP SEA
Auto start-up. Mains failure	✓
Manual start-up	✓
Remote start-up	✓

Alarms

Start-up failure	✓
Battery charge failure	✓
Low oil pressure	✓
High engine water temperature	✓
Low fuel level	✓
Low radiator water level	✓
Emergency stop	✓
Overspeed	✓

Standby Gensets	
3-phase tracking card	✓
Battery charger maintainer	✓
Voltmeter. Switch: PHASE-MAINS-GENSET	✓
Auto/manual function	✓
LED indicators MAINS/GENSET switch	✓
Remote control software	✓
RS 485 communication port	✓
Protection Devices	
Emergency stop button	✓
ATS	4P 800A 400/230V

Head office address:

Unit 4, Concorde Close, Sopwith Park,
 Segensworth North, Fareham, Hampshire, PO15 5RT. UK
 Tel: +44 (0)1489 560700 Fax: +44 (0)1489 560742
sales@powertecnicque.com www.powertecnicque.com

Power Tecnicque Ltd reserves the right to modify any characteristic without prior notice. Photos or drawings are based on standard product, being possible to add optional elements