

**power**technique

**PT275**

Voltage (V): **400/230**

Frequency (Hz): **50**

**STATIONARY OPENSET  
AUTOMATIC WITHOUT ATS**

## Technical Information

PRP Power (Kva)	<b>250</b>
Standby Power	<b>275</b>
PRP Power (Kw)	<b>200</b>
Standby Power (Kw)	<b>220</b>
Model	<b>STATIONARY OPENSET</b>

Weight and Dimensions (mm)	
Length (L)	<b>2900</b>
Width (W)	<b>1100</b>
Height (H)	<b>2057.5</b>
Weight (kg)	<b>2525</b>
Fuel tank capacity (l)	<b>415</b>

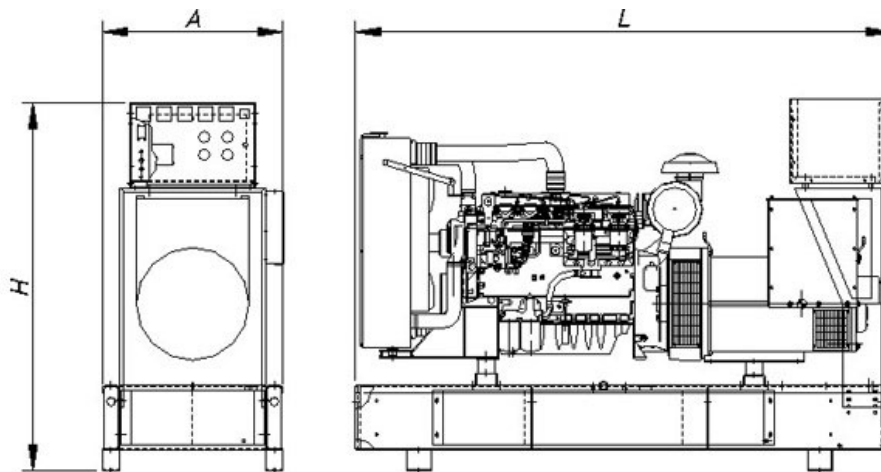

## Consumption

	PRP Power		Standby Power	
	L/h	Range (hours)	L/h	Range (hours)
25%	14.5	2	16.3	25.5
50%	27.7	15	31.1	13.3
75%	38.8	10.7	43.1	9.6
100%	48.6	8.5	54.3	7.6

## Engine

Brand	VOLVO
Model	TAD 734 GE
No. of Cylinders	6
Engine Capacity	7150
Bore (mm)	108
Stroke (mm)	130
Compression ratio	17:1
Water cooled	✓
Speed (r.p.m.)	1500
Preheating system	✓
Fuel tank capacity (l)	415

### Cooling System

Flow of air from fan (m3/min)	220
-------------------------------	-----

### Lubrication System

Oil sump capacity (l)	29
Maximum oil consumption (%fuel consumption)	0.1

### Air Intake System

Aspirated air flow (m3/min)	16.3
-----------------------------	------

### Electrical System

Batteries	12V 120 Ah
-----------	------------

### Exhaust System

Input diameter (")	3.5
Output diameter (")	3.5
Exhaust diameter (mm)	300
Exhaust length (mm)	1,645
T <sup>a</sup> gas emission (°C)	550
Gas flow	33.4

## Alternator

Model	UCDI 274 K1
Electronic Regulation	✓
AVR	SX460
Power (Kva)	275

## Electric Panel

### Measuring Instruments

Voltmeter	1
Battery current gauge	✓

### Control Instruments

Control card	DEEP SEA
Auto start-up. Mains failure	✓
Manual start-up	✓
Remote start-up	✓

### Alarms

Start-up failure	✓
Battery charge failure	✓
Low oil pressure	✓
High engine water temperature	✓
Low fuel level	✓
Low radiator water level	✓
Emergency stop	✓
Overspeed	✓

<b>Standby Gensets</b>	
3-phase tracking card	✓
Battery charger maintainer	✓
Voltmeter. Switch: PHASE-MAINS-GENSET	✓
Auto/manual function	✓
LED indicators MAINS/GENSET switch	✓
Remote control software	✓
RS 485 communication port	✓
<b>Protection Devices</b>	
Emergency stop button	✓

**Head office address:**

Unit 4, Concorde Close, Sopwith Park,  
 Segensworth North, Fareham, Hampshire, PO15 5RT. UK  
 Tel: +44 (0)1489 560700 Fax: +44 (0)1489 560742  
[sales@powertecnicue.com](mailto:sales@powertecnicue.com) [www.powertecnicue.com](http://www.powertecnicue.com)

Power Tecnicue Ltd reserves the right to modify any characteristic without prior notice. Photos or drawings are based on standard product, being possible to add optional elements